

XFIOW

INVERSilence™ Tech

INVERTER POOL PUMP

INSTALLATION & OPERATION MANUAL

Model: GFVS09N/ GFVS11N/ GFVS15N/ GFVS19N

Thank you for purchasing our inverter pool pumps, this manual contains important information that will help you in operating and maintaining this product. Please read the manual carefully before installation & operation and retain it for future reference.



AQUAGEM®

CONTENTS

1. IMPORTANT SAFETY INSTRUCTIONS.....	1
2. TECHNICAL SPECIFICATIONS	1
3. OVERALL DIMENSION	2
4. INSTALLATION.....	2
5. SETTING & OPERATION	4
6. WIRING CONNECTION	6
7. EXTERNAL CONTROL (Not included in standard model)	7
8. TROUBLE SHOOTING	8
9. ERROR CODE.....	9
10. MAINTENANCE.....	9
11. WARRANTY & EXCLUSIONS	10
12. WEEE LEGISLATION	10

1. IMPORTANT SAFETY INSTRUCTIONS

This guide provides installation and operation instructions for this pump. Consult your supplier with any questions regarding this equipment.

1.1 When installing and using this electrical equipment, basic safety precautions should always be followed:

- RISK OF ELECTRICAL SHOCK. Connect only to a branch circuit protected by a ground-fault circuit-interrupter (GFCI). Contact a qualified electrician if you cannot verify that the circuit is protected by a GFCI.
- This pump is for use with permanent installed in ground or above ground swimming pools and may also be used with hot tubs and spas if so marked. Do not use with above ground pools that can be readily disassembled for storage.
- The pump is not submersible.
- Before servicing the pump; switch off power to the pump by disconnecting the main circuit to the pump.
- Never open the inside of the drive motor enclosure.

1.2 All installations must be fitted with earth leakage or residual current protection devices, having a rated residual operating current not exceeding 30mA.

WARNING:

- Do not run the pump dry. In case of dry run, mechanical seal will be damaged and the pump will start leaking. Fill the pump with water before starting.
- Before servicing the pump, switch OFF power to the pump by disconnecting the main circuit to the pump and release all pressure from pump and piping system.
- Never tighten or loosen screws while the pump is operating.
- Do not block the pump suction.

1. TECHNICAL SPECIFICATIONS

Model	Advised pool volume (m ³)	P1	Voltage	Current	Backwash		Circulation		
		kw		A	Qmax	Hmax	at 6m	at 8m	at 10m
GFVS09N	20~30	0.05~0.32	220~240v 1ph	0.79~3.0	18.5	10	5.4~7.2		
GFVS11N	25~35	0.07~0.45		0.91~3.67	21.0	12	7.3~12	7.5~8.2	
GFVS15N	30~55	0.1~0.73		0.98~5.38	30.0	17	6.3~18.1	6.4~14.5	7.5~10.3
GFVS19N	50~80	0.13~1.0		1.30~7.29	33.7	21	8.16~24	8.5~20.5	7.1~16.3

2. OVERALL DIMENSION

2.1 GFVS09N & GFVS11N

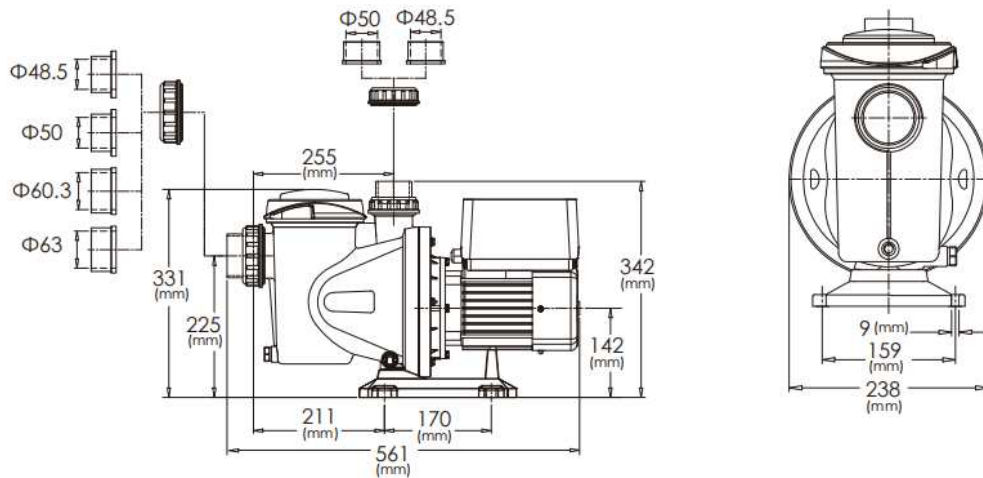

3.2 GFVS15N & GFVS19N

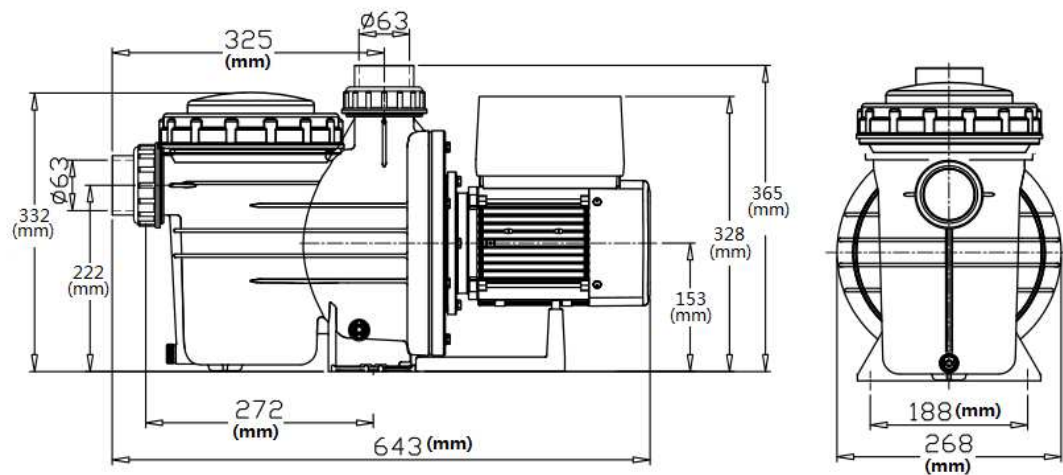

4. INSTALLATION

4.1. Pump Location

1. Locate pump as close to pool as practical and run suction lines as direct as possible to reduce friction loss.
2. To avoid direct sunshine or heat, It is recommended to place pump indoor or in the shade.
3. Do NOT install pump in a damp or non-ventilated location. Keep motor clean. Pump motors require free circulation of air for cooling.

4.2. Piping

- 1). For improved pool plumbing, it is recommended to use a larger pipe size. When installing the inlet and outlet fittings (male adaptor), use thread sealant.
- 2). Piping on the suction side of the pump should be the same or larger than the return line

diameter.

3). Plumbing on the suction side of the pump should be as short as possible.

4). For most installations we recommend installing a valve on both the pump suction and return lines so that the pump can be isolated during routine maintenance. However, we also recommend that a valve, elbow or tee installed in the suction line should be no closer to the front of the pump than five times the suction line diameter.

4.3. Valves and Fittings

1). Do not install 90° elbows directly into pump inlet. Elbows should be no closer than 250mm to the inlet. Joints must be tight. Suction line diameter must equal or be larger than the discharge line diameter.

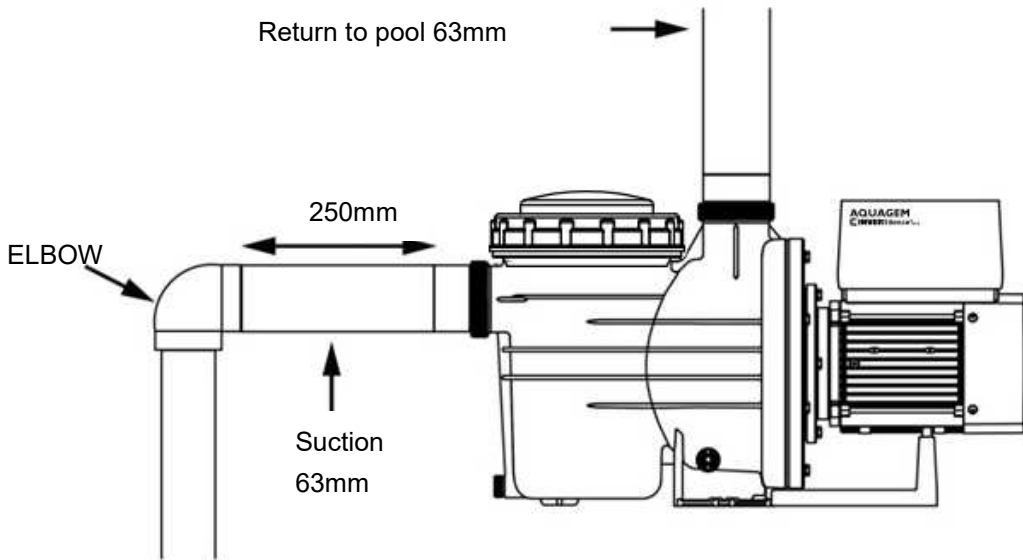

Please note the inlet and outlet for GFVS15N/GFVS19N is 63mm, while for GFVS09N/GFVS11N, the inlet could be 50/63mm, outlet is 50mm.







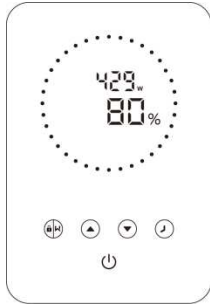

2). Flooded suction systems should have gate valves installed on suction and discharge pipes for maintenance, however, the suction gate valve should be no closer than five times the suction pipe diameter as described in this section.

3). Use a check valve in the discharge line when using this pump for any application where there is significant height to the plumbing after the pump.

4). Be sure to install check valves when plumbing in parallel with another pump. This helps prevent reverse rotation of the impeller and motor.

5. SETTING & OPERATION









5.1 Interface

Manual Mode	Timer Mode	Backwash Mode	Description	
				On/off
				Lock/Backwash: When the screen is locked, press >3 seconds to unlock the screen; When the screen is unlocked, press it for backwash mode.
				Up: Increase value(capacity& time)
				Down: Decrease value(capacity& time)
				Timer: Switching from manual to Timer mode
			%	Capacity: 40~100%

5.2 Capacity Setting



Note: The inverter module can be operated manually or automatically at regular intervals.

The system automatically saves the 4 latest valid settings.

NO.	Buttons Used	Comments
1		Press >3 seconds to unlock the screen; Press <3 seconds for backwash mode; Under backwash mode, pump will count down in 180s, use  or  to adjust backwash time from 30-900s.
2		Press the button to start. The pump will run at full capacity (100%) .
3	 	Use  or  to adjust by 5% to a specific running capacity if needed.



5.3 Timer Setting

*Overlap setting of time will be considered as invalid, the pump will only run based on the previous valid setting.

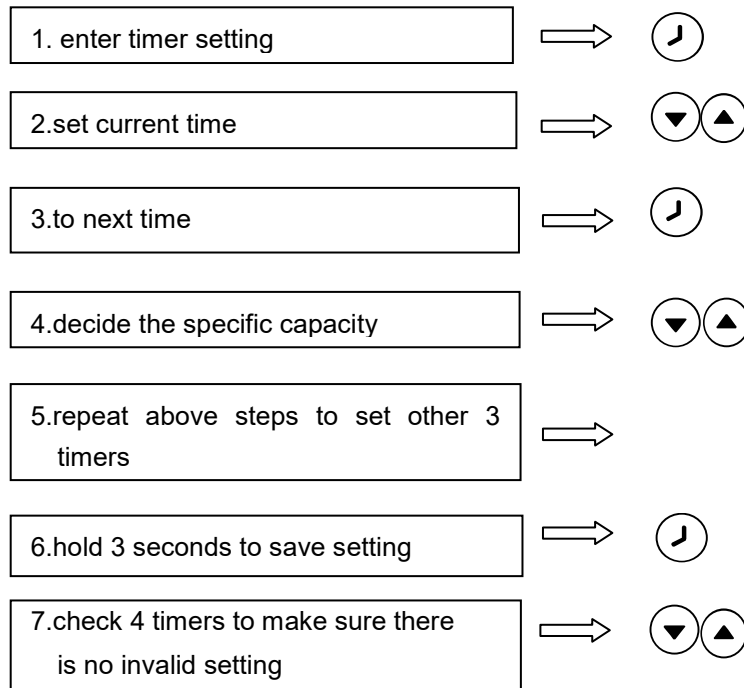
*During timer setting, if you want to return to the previous setting, hold   for 3 seconds.



5.4 Parameter Setting

Under OFF mode, hold   for 3 second to enter parameter settings.

Parameter	Description	Default Setting	Setting Range
1	Di2	100%	40%~100%, by 5% increments
2	Di3	80%	
3	Di4	40%	

6. WIRING CONNECTION



Warning:

All electrical wiring **MUST** conform with applicable **National Electrical Safety Code (NESC)** and **National Electric Code (NEC)**.

Please refer to the below schematic for information on how to correctly install your pump.

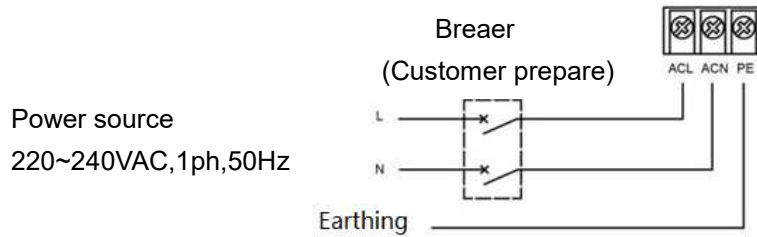
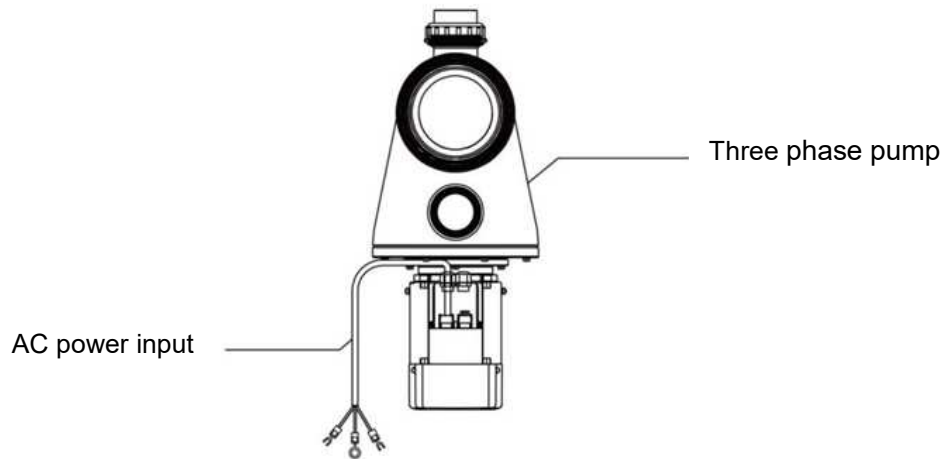
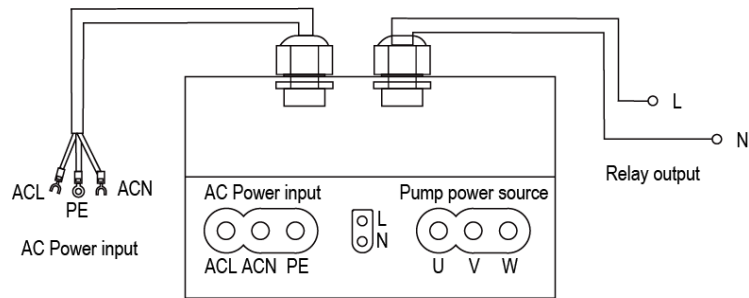

7. EXTERNAL CONTROL (Not included in standard model)

External control can be enabled via following contacts. Pressing on/off can stop the pump even if working via an external controller.

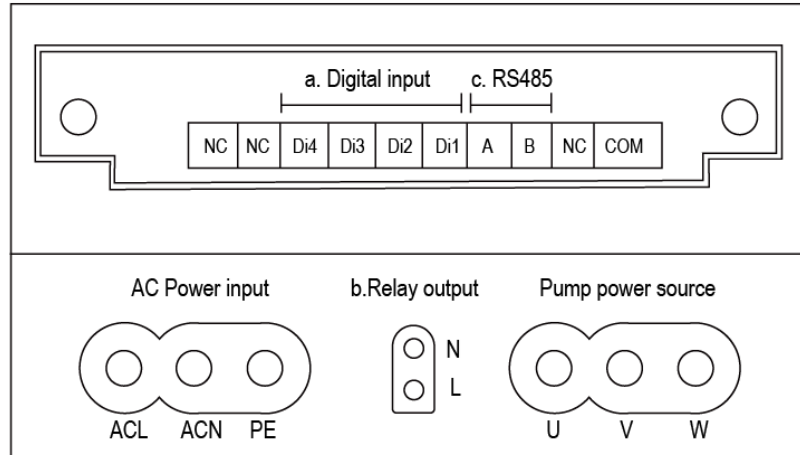

- a. **Digital Input:** To enable external speed control, connect one of the digits from Di1/2/3/4 to COM. See schematic as below:

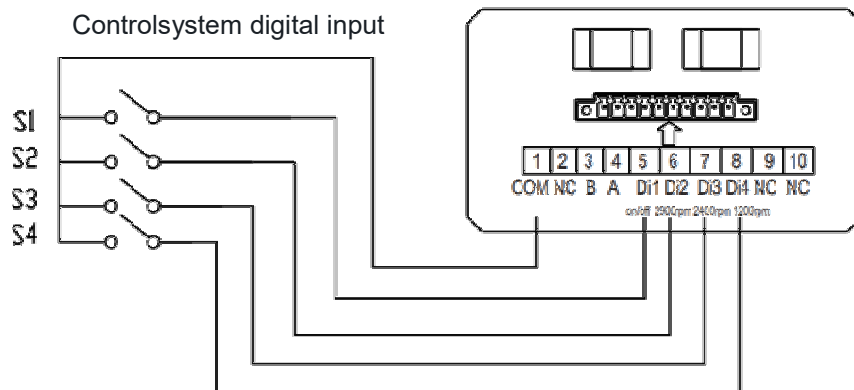

- b. **Relay Output:** Connect terminal L & N to enable external control. An additional on-off is necessary while bearing power is less than 500W (2.5A). See schematic as below:

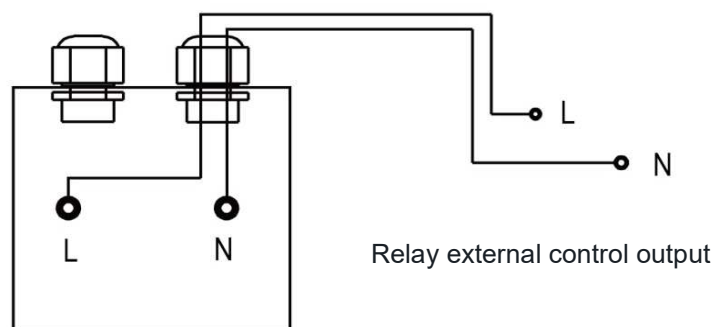

- c. **RS485:** To enable external control pump running capacity, connect terminal A and B, via Modbus485 communication protocol.

Display board

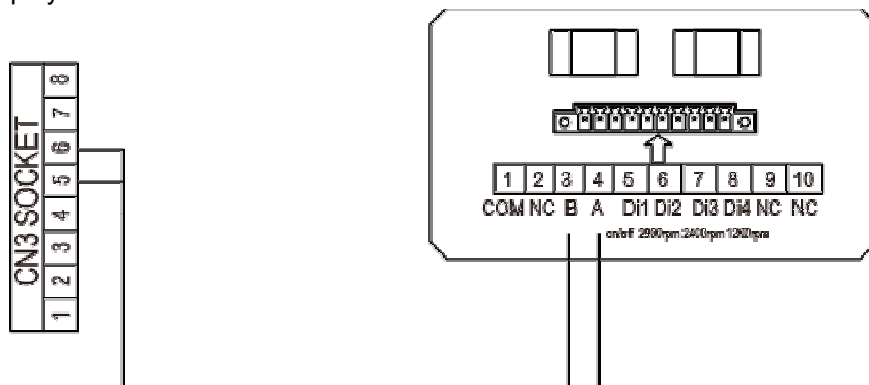

RS485

8. TROUBLE SHOOTING

Problem	Corrective solution
Pump Does Not Start	<ul style="list-style-type: none"> •Power Supply fault, disconnected or defective wiring • Fuses blown or thermal overload open • Check the rotation of the motor shaft for free movement and lack of obstruction. • Motor windings burned out.
Pump Won't Prime	<ul style="list-style-type: none"> •Empty pump/strainer housing. Make sure the pump/strainer housing is filled with water and the cover o ring is clean. •Loose connections on the suction side. •Strainer basket or skimmer basket loaded with debris. •Suction side clogged.
Low Water Flow	<ul style="list-style-type: none"> •Pump is not primed •Air entering suction piping •Basket full of debris •Inadequate water level in pool
Pump being noisy	<ul style="list-style-type: none"> •Air leak in suction piping, cavitations caused by restricted or undersized suction line or leak at any joint, low water level in pool, and unrestricted discharge return lines. • Disassemble pump, clean impeller, follow pump service instructions for reassembly. •Vibration due to improper mounting, etc.

9. ERROR CODE

Item	Code	Description	Analysis
1	E001	Abnormal input voltage	Not faulty
2	E002	Output over current	Not faulty
3	E101	Heat sink over heat	Contact your supplier
4	E102	Heat sink sensor error	Contact your supplier
5	E103	Master driver board error	Contact your supplier
6	E201	Circuit board error	Contact your supplier
7	E202	Master board EEPROM reading failure	Contact your supplier
8	E203	RTC time reading error	Contact your supplier
9	E204	Display board EEPROM reading failure	Contact your supplier
10	E205	Communication error	Contact your supplier
11	AL01	Auto speed reduction against high temperature	Contact your supplier

Note:

1. AL01 is not an error indication: when it appears the inverter will automatically switch to a lower capacity to self protect against high internal temperature. When the temperature drops back to 68°C the inverter will resume at the preset speed.
2. When causes for E002/E101/E103 lifts, the device will resume working automatically, however when it appears a fourth time, the device will stop working, to resume operation, unplug the device and plug in & restart again.

10. MAINTENANCE

Emptying the strainer basket, the basket should be inspected frequently through the transparent lid and emptied when a build-up of rubbish is evident. The directions below should be followed:

1. Switch off pump.
2. Unscrew the strainer basket lid anti-clockwise and remove.
3. Remove the strainer basket by lifting upwards from its housing.
4. Empty the trapped refuse from the basket. Hose out with water if necessary.

NOTE: Do not knock the plastic basket on a hard surface as it will cause damage.

5. Check the strainer basket for cracks, replace the basket in the pump if OK.
6. Replace the lid and ensure that it seals on the large rubber O-ring. Firm hand tightness only is required.

NOTE: Failure to undertake regular maintenance may cause damage not covered by warranty.

11. WARRANTY & EXCLUSIONS

Should a defect become evident during the term of warranty, at its option, the manufacturer will repair or replace such item or part at its own cost and expense. Customer will need to follow the warranty claim procedures in order to obtain the benefit on this warranty.

Under no circumstances should the manufacturer be held liable for any consequences resulting from inappropriate, incorrect installation, or mismatching of the product to pool pumps that are not compatible.

12. WEEE LEGISLATION



When disposing the product, please hand it over to a designated collection point for the recycling of waste electrical and electronic equipment.

The separate collection and recycling of waste equipment at the time of disposal will help ensure that it is recycled in a manner that protects human health and the environment. Contact your local authority for information on where you can drop off your waste for recycling.

P5B-1